

# **SKID STEER POWER RAKES MANUAL**

**Model: PR-12-72W**



# Content

<b>I . Preface .....</b>	<b>1</b>
<b>II . Security Statement .....</b>	<b>2</b>
<b>III. Warning Label .....</b>	<b>4</b>
<b>IV. Technical Parameter .....</b>	<b>5</b>
<b>V . Installation .....</b>	<b>7</b>
<b>VI. Operation .....</b>	<b>8</b>
<b>VII. Hydraulic Electric Control System .....</b>	<b>15</b>
<b>VIII. Maintenance .....</b>	<b>18</b>

## I . Preface

All products are designed to give safe, dependable service if they are operated and maintained according to instructions. Read and understand this manual before operation.

This manual has been prepared to assist the owner and operators in the safe operation and suitable maintenance of the equipment. The information was applicable to products at the time of manufacture and does not include modifications made afterwards.

Read and understand this operator's manual before attempting to put equipment into service. Familiarize yourself with the operating instructions and all the safety recommendations contained in this manual and those labeled on the equipment and on the skid steer. Follow the safety recommendations and make sure that those with whom you work follow them.

All products are designed to give safe, dependable service if they are operated and maintained according to instructions. Read and understand this manual before operation. It is the owner's responsibility to be certain anyone operating this product reads this manual and all other applicable manuals to become familiar with this equipment and all safety precautions. Failure to do so could result in serious personal injury or equipment damage. If you have any questions, consult your dealer.

## II . Security Statement

### **SAFELY MAINTAIN AND REPAIR EQUIPMENT**

- Do not wear loose clothing, or any accessories that can catch in moving parts. If you have long hair, cover or secure it so that it does not become entangled in the equipment.
- Work on a level surface in a well-lit area.
- Use properly grounded electrical outlets and tools.
- Use the correct tool for the job at hand. Make sure they are in good condition for the task required.

### **WARNING! SAFELY OPERATE EQUIPMENT**

- Keep all step plates, grab bars, pedals, and controls free of dirt, grease, debris, and oil.
- Never allow anyone to be around the equipment when it is operating.
- Do not operate the equipment from anywhere other than the correct operators position.
- Never leave equipment unattended with the engine running or with this attachment in a raise position.
- Do not alter or remove any safety feature from the prime mover or this attachment.

### **EQUIPMENT SAFETY PRECAUTIONS**

It is recommended to use dust suppression, dust collection and if necessary personal protective equipment during the operation of any attachment that may cause high levels of dust.

### **REMOVE PAINT BEFORE WELDING OR HEATING.**

Hazardous fumes/dust can be generated when paint is heated

by welding, soldering or using a torch. Do all work outside or in a well-ventilated area and dispose of paint and solvent properly. Remove paint before welding or heating.

When sanding or grinding paint, avoid breathing the dust. Wear an approved respirator.

If you use solvent or paint stripper, remove stripper with soap and water before welding.

Remove solvent or paint stripper containers and other flammable material from area. Allow fumes to disperse at least 15 minutes before welding or heating.

**END OF LIFE DISPOSAL.**

At the completion of the useful life of the unit, drain all fluids and dismantle by separating the different materials (rubber, steel, plastic, etc.).

### III. Warning Label



<b>LandHonor</b> POWERFUL ATTACHMENT TOOLS	
Model	PR-12-72W
Weight	1300 lbs
Serial NO.	HL*****
Max pressure	3000 PSI
Raking Width	72 in
Flow Range	15-25 GPM
Year	202*
Email: <a href="mailto:service@landhonor.com">service@landhonor.com</a> 	

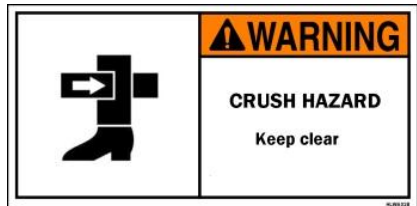

## IV. Technical Parameter

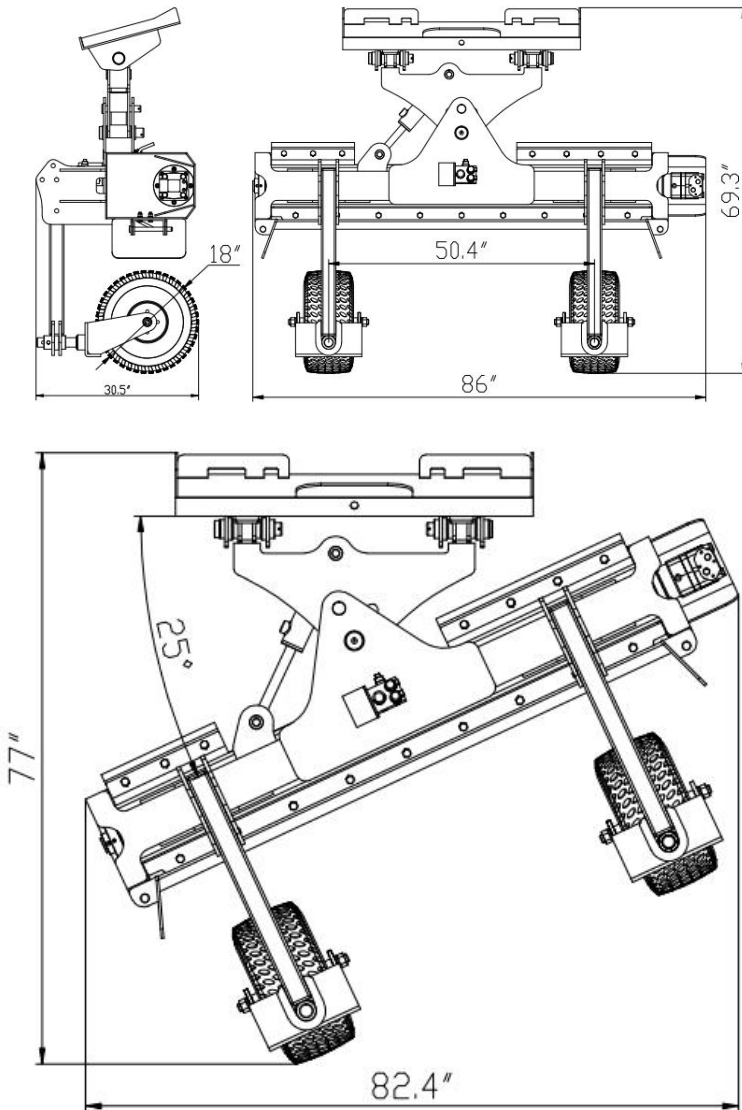

No.	Item	Parameter	Remark
1	Overall Length	69.3"	model: HL-PR-0072 W
2	Overall wide	86"	
3	Overall heigh	30.5"	
4	Roller Width	72"	
5	Raking Width (full angle)	68"	
6	Number of stations	88	Carbide tooth tip
7	Rotation Left & Right	± 25°	
8	Tilt Up or Down:	22°	
9	Hydraulic Flow Required	15-25GPM	
10	Max. pressure of oil	2000-3000 psi	
11	Torque at 2,500	530 ft-lbs	
12	Maximum drum speed	300r/min	
13	Direct Current Voltage	DC12V	
14	hydraulic cylinder	2.5"x1.25"x8"	Stroke 8"
15	Tire Size	18 x 8-1/2 x 8	
16	hydraulic control valve Flow	25GPM	
17	hydraulic control valve pressure	3500 psi	
18	mounted bearings	UCF310	
19	deep groove ball bearing	6916-2RS	
20	deep groove ball bearing	6205-2RS	
21	Weight	1112lbs	

## V. Installation

The power rake (Hydraulic angling) is shipped assembled. The only adjustment is to install the casters to the working position.

Initial Set-up and Systems Check:

1. Always check with your Loader manual or dealer for counter weight ballast that may be required for machine stability.
2. Air in hydraulic systems can cause erratic operation and allows loads or equipment components to drop unexpectedly.
3. Before operating equipment purge any air in the system by engaging all hydraulic functions.
4. Check that all control lever positions function as instructed in the Operator's Manual. Do not operate until control lever and equipment movements are correct.
5. Make sure all hydraulic hoses, fittings, and valves are in good condition and not leaking before starting power unit. Check and route hoses carefully to prevent damage.
6. Hoses must not be twisted, bent sharply, kinked, frayed, pinched, or come into contact with any moving parts.
7. Operate moveable components through full operational range to check clearances. Replace damaged hoses immediately.
8. Ensure implement is properly attached, adjusted, and in good condition. Loader coupler lock-pins must be fully extended and properly engaged into attachment retaining slots.
9. If the loader is equipped with ROPS and seat belt/operator restraint, keep ROPS systems in place and keep seat belt/operator restraint securely fastened/engaged. Falling off Loader can result in death from being run over or crushed.

## VI. Operation

### INTENDED USE

This power rake is designed for removing rock, small debris and for thatching. Use in any other way is considered contrary to the intended use.

### **WARNING! IMPROPER OPERATION CAN CAUSE THE MACHINE TO TIP OR ROLL OVER AND CAUSE INJURY OR DEATH.**

1. Keep Loader lift arms and attachment as low as possible.
2. Do not travel or turn with Loader lift arms and attachment raised.
3. Turn on level ground.
4. Go up and down slopes, not across them.
5. Keep the heavy end of the machine uphill.
6. Do not overload the machine.
7. Never use the Loader attachment to carry loads that exceed Loader rated operating capacity or other Loader specifications. Check your Loader manual or with your dealer for Loader rated operating capacity. Exceeding this capacity can cause machine to tip or roll over and cause injury or death.
8. Use of a front safety door, if equipped, on the Loader is recommended for operation of the Power Box Rake.
9. Only engage power when equipment is at ground level. Always disengage power when equipment is raised off the ground.
10. Do not disconnect hydraulic lines until all system pressure is relieved.
11. Hydraulic system leak down, hydraulic system failures, mechanical failures, or movement of control levers can cause equipment to drop or rotate unexpectedly and cause severe

injury or death.

12. Never direct discharge toward people, animals, or property.

13. Do not operate equipment while under the influence of alcohol or drugs.

14. Operate only in the daylight or good artificial lighting.

15. Always comply with all state and local lighting and marking requirements.

16. Ensure equipment is properly attached, adjusted, and in good operating condition. Loader coupler lock-pins must be fully extended and properly engaged into attachment retaining slots.

### **WATCH FOR OPERATING HAZARDS**

1. Look down and to the rear and make sure area is clear before operating in reverse.

2. Watch for hidden hazards on the terrain during operation.

3. Use extreme care when working close to fences, ditches, other obstructions, or on hillsides.

4. Reduce ground speed on slopes and rough terrain.

5. Do not operate on steep slopes.

6. Do not stop, start, or change directions suddenly on slopes.

7. Stop Loader and implement immediately upon striking an obstruction. Dismount Loader using proper procedure. Inspect and repair any damage before resuming operation.

### **ATTACHING POWER RAKE TO LOADER**

Read the loader Operator's Manual connecting and removing instruction.

1. Cycle attachment drive control to relieve residual pressure at hydraulic couplers.

2. Position attachment on level surface with enough space

behind it to accommodate unit.

3. Position hydraulic hoses so they will not be pinched when connecting the power rake.
4. Connect hydraulic hoses to loader auxiliary quick couplers.
5. Ensure that connections are secure by pulling on hoses.
6. Move to the loader operator's position and start engine.
7. Lower the loader lift arms to their lowest position and tilt mount plate forward.
8. Raise lift arms while tilting back mount plate. (figure 2)
9. Roll the loader coupler into the power rake so the coupler handles can be engaged.
10. Turn ignition switch off, set brake, and remove key.

### **OPERATION**

Start prime mover engine.

Lower power rake slowly to the ground.

Engage hydraulic control lever for auxiliary implements.

Increase engine rpm to give desired rpm at the roller. Normal operating speed is approximately 270 rpm. If operating in heavy rock, reduce the speed slightly.

Move the prime mover forward or backward as desired. For the roller to operate effectively, it must rotate in the opposite direction of the prime mover wheels. Roller rotation direction is controlled by prime mover hydraulic controls.

### **GROUND SPEED**

Ground speed should be between 3 and 5 mph under normal conditions. In heavy rock, reduce the ground speed to 1 to 3 mph.

### **OPERATION**

Roller should be level with the ground. The power rake should

also be level with the ground front to back.

To accomplish this, raise or lower casters and/or use the prime mover tilt cylinder.

To allow the roller to penetrate deeper into the ground, remove the bail pin and raise the casters. Re-pin in new position. To achieve the opposite, lower the casters.

During operation, further depth control can be achieved by tilting the rake forward on the casters to raise roller, or by tilting the rake back to raise casters and allow more roller penetration. Be sure to check the air pressure in each tire regularly so that an even, consistent grade will be maintained.

The normal gap between the roller and barrier for average conditions is about 1-1/4". This gap can be adjusted either wider or narrower by loosening that holds the barrier mount and sliding it up or down. A wider opening will allow more dirt and rock to pass through. For finer raking, reduce the gap. Be careful not to let roller hit barrier.

The roller on the power rake is bi-rotational. You can operate the roller in both directions clockwise and counter-clockwise. The roller operates most efficiently when it rotates in the opposite direction of the prime mover wheels.

### **OPERATING DEPTH**

When power raking, the depth will determine how much dirt is carried ahead of the roller. The ideal depth will vary with conditions and can be anywhere from skimming the surface to about 3" deep. See instructions in Power Roller above to set roller depth.

When making the first windrow the level of dirt may be halfway up on the barrier. When moving the windrow two or three times, the level of the dirt may be to the top of the barrier.

However, try to prevent material from flowing over the top. The power rake allows fast raking of large areas of ground by being able to move windrows several times. Of course, the volume or density of the material being raked will dictate how many times a windrow can be moved.

The function of the endplates is to contain the material in front of the roller while the clean material passes between the roller and barrier.

With the endplates mounted in the working position and the roller straight (parallel with prime mover), material can be moved along, filling in the low spots. By decreasing the gap between the roller and barrier, more material can be pulled along. Barrier adjustment is

These plates can be mounted to the front or back of the power rake, depending on the raking direction. When you move the endplates from front to back, you can move the left one to the right side and the right one to the left side.

Make sure the disconnected power rake is stored on a hard, level surface. Use the endplates mounted on attachment side of rake to ensure stability.

Operator Production Successful operation of the power rake will come with operator experience. The rake's performance also depends on the type and size of the prime mover it's mounted on.

An operator that masters the technique of adjusting the angle of attack of the roller against the soil will also find ideal settings under various conditions to give the desired results. The power rake is capable of many applications. The following are some of the common applications:

Pulverizing Topsoil. Debris Removal. Spreading Fill and Topsoil.

Thatching Existing Grass Areas.

### **SHUTTING DOWN**

Lower the lift arms and power rake to the ground. Purge any air in the system. Hydraulic system leak down, hydraulic system failures, mechanical failures, or movement of control levers can cause equipment to drop or rotate unexpectedly.

Shut off engine, set brake and remove key. Removing Power Rake from Prime Mover. Install endplates on attachment side of power rake. On a hard level surface, lower attachment to the ground. Shut off engine, set brake and remove key.

Move attachment coupler latches to the unlocked position (lock pins must be disengaged).

Disconnect hydraulic hoses from quick couplers. Install dust plugs and couple hoses together for storage.

Disconnect direction control switch from prime mover power cord and remove switch. Move to the operator's position and start engine. Release brake and roll attachment coupler until it is disengaged from the attachment. The attachment should rest in a stable position for storage.

### **STORAGE**

Make sure the disconnected power rake is stored on a hard, level surface. Endplates mounted on attachment side of rake increase stability

- Clean the unit thoroughly, removing all mud, dirt and grease.
- Inspect for visible signs of wear, breakage or damage. Order any parts required and make the necessary repairs to avoid delays upon removal from storage.
- Tighten loose nuts, caps crews and hydraulic connections.
- Coat exposed portions of the cylinder rods with grease.

- Lubricate grease fittings.
- Seal hydraulic system from contaminants and secure all hydraulic hoses off the ground to help prevent damage.
- Store unit in a dry and protected place. Leaving the unit outside will materially shorten its life. Additional Precautions for Long Term Storage:
  - Touch up all unpainted surfaces with paint to avoid rust.
  - Inflate tires to recommended tire pressure.

## VII. Hydraulic Electric Control System

### DIRECTIONAL CONTROL VALVE (HYDRAULIC ANGLE MODEL ONLY)

A three-position switch (normally open) is used to operate the direction control valve. Control power (12 volt) is supplied by the power cord attached to the prime movers electrical system. The switch wires are connected to the direction control valve. The direction control valve uses a small amount of hydraulic oil bypassed from the roller drive motor circuit. The direction control valve uses a small amount of hydraulic oil bypassed from the roller drive motor circuit. The prime movers auxiliary hydraulic system must be connected and engaged to provide angle direction adjustment. The roller must be rotating clockwise.

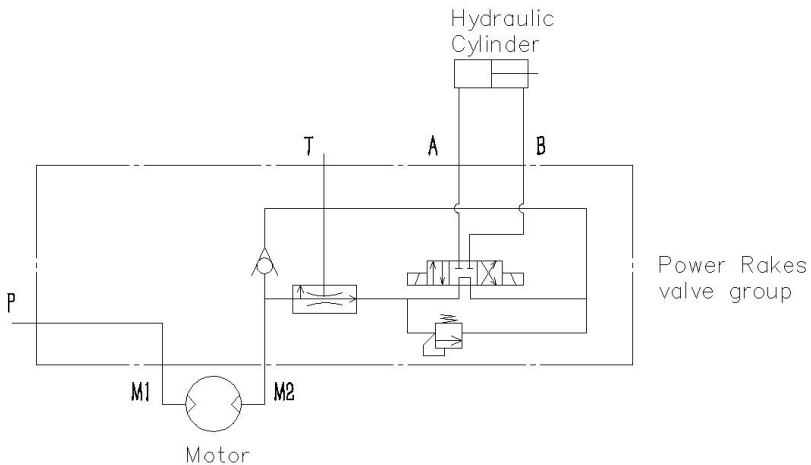

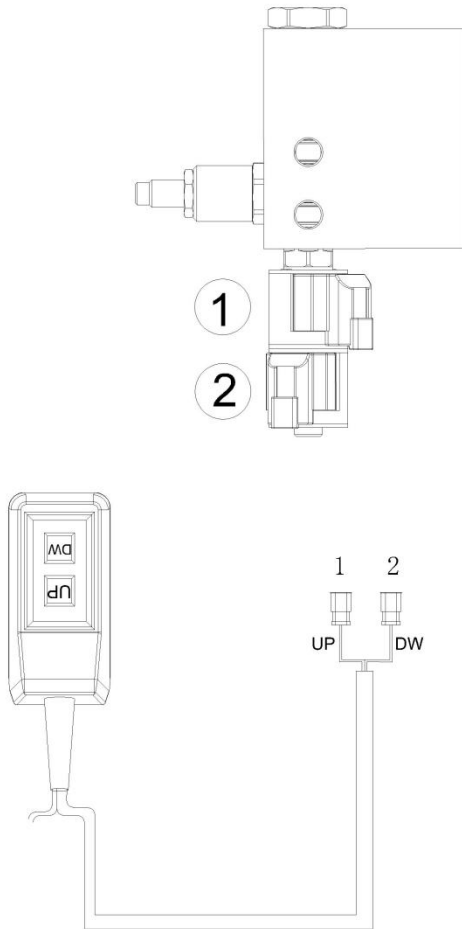

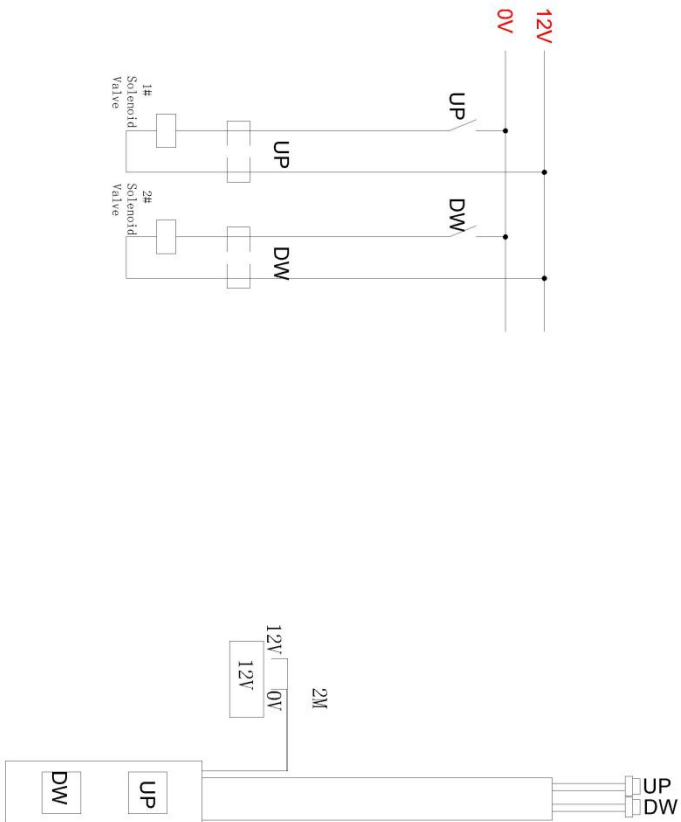

## **VIII. Maintenance**

Regular preventive maintenance and immediate repair of broken or worn parts will ensure maximum efficiency and long life.

Because of the nature of the jobs the power rake does, site preparation and rock raking, the power rake is constantly vibrating and shaking. Parts may loosen as it is used. One of the most important functions an operator can perform is observing and inspecting the equipment for loose or worn parts to prevent damage or excessive downtime.

### **MAINTENANCE SAFETY**

1. Your dealer can supply original equipment hydraulic accessories and repair parts. Substitute parts may not meet original equipment specifications and may be dangerous.
2. Avoid electrical system hazards. Never work on the electrical system unless you are qualified and thoroughly familiar with system details and the special handling requirements.
3. Disconnect battery before working on electrical system. Remove "ground" cable first. When reconnecting battery, connect "ground" cable last.
4. Never perform service or maintenance with engine running.
5. Tighten all bolts, nuts, and screws, and check that all cotter pins are installed securely to ensure equipment is in a safe condition before operating.

### **HYDRAULIC MOTOR REMOVAL**

1. Make sure all pressure is relieved for hydraulic hoses. Remove hydraulic hoses from motor.
2. Remove two bolts holding the motor bucket assembly and

slide out of the roller.

3. Remove four bolts holding hydraulic motor to motor bucket. It will be necessary to have a lifting device or additional help while removing and replacing the roller. The roller weighs approximately 80 lbs.

4. Remove two bolts holding the motor bucket assembly and slide the hydraulic motor out of the roller.

5. Loosen the bolt on the bearing tube of the non-drive end.

6. Slide roller and bearing out of frame.

7. Remove hex bolt, bearing cap, bearing, and protective collar from roller.

8. On roller to be installed, place machine bushing and protective collar against end plate on roller.

9. Place bearing and bearing cap on roller. Clamp in place with hex bolt and lock washer into end of roller shaft. Verify bearing is centrally located in clamp tube.

10. Position roller and bearing into bearing retainer on non-drive end of frame. Tighten bearing cap at this time.

11. Install motor bucket assembly onto frame and into hex drive of roller. Tighten hardware.

12. Check that roller clears the frame on both ends.

13. Run power rake and watch for any interference between roller frame.

**TROUBLESHOOTING**

<b>PROBLEM</b>	<b>CAUSE</b>	<b>SOLUTION</b>
<b>Roller will not turn</b>	Hydraulic valve on Loader not engaged	See Loader Operator’s Manual for auxiliary hydraulic operation procedure
	Relief valve setting on Loader not properly adjusted	Have Loader dealer set relief valve at correct pressure
	Worn, damaged, insufficient or inadequate pump	Repair or replace hydraulic pump
	Insufficient oil in system	Service the Loader hydraulic reservoir
	Hose ends not completely engaged	Check hose coupling and engage properly
	Air in hydraulic lines	Cycle Loader auxiliary system several times to remove air from lines
	Obstruction in hydraulic lines	Replace obstructed or damaged line
	Obstruction between roller and barrier	Reverse roller to clear obstruction
<b>Oil leaks</b>	Worn or damaged seal	Replace leaking seal
	Loose or damaged hoses	Replace damaged hoses and secure loose hoses
	Loose or damaged connections	Replace damaged hose connections and tighten

		loose fittings
<b>Angle cylinder will not extend or retract</b>	Electrical failure	See Loader Operator's Manual
	Hydraulic system not activated	Engage roller drive motor before attempting to move angle cylinder
<b>Angle cylinder will not hold position</b>	Check valve in manifold	Malfunctioning Repair or replace check valve
	Solenoid cartridge not returning to closed position	Repair or replace solenoid cartridge

**BOLT TORQUE SPECIFICATIONS**

Use the following charts when determining bolt torque specifications when special torques are not given. Always use grade 8.8 or better when replacing bolts.

**METRIC BOLT TORQUE SPECIFICATIONS**

The following torque values are for use with metric Bolt head identification marks as per grade. hardware that is unplated and either dry or lubricated with engine oil. Reduce torque 15% when using hardware that has extreme pressure lubricants, plating or hard washer applications.

Ⓐ Diameter & Thread Pitch (Millimeters)	Wrench Size	COARSE THREAD				FINE THREAD				Ⓐ Diameter & Thread Pitch (Millimeters)
		MARKING ON HEAD				MARKING ON HEAD				
		Metric 8.8		Metric 10.9		Metric 8.8		Metric 10.9		
		N-m	lbs-ft	N-m	lbs-ft	N-m	lbs-ft	N-m	lbs-ft	
6 x 1.0	10 mm	8	6	11	8	8	6	11	8	6 x 1.0
8 x 1.25	13 mm	20	15	27	20	21	16	29	22	8 x 1.0
10 x 1.5	16 mm	39	29	54	40	41	30	57	42	10 x 1.25
12 x 1.75	18 mm	68	50	94	70	75	55	103	76	12 x 1.25
14 x 2.0	21 mm	109	80	151	111	118	87	163	120	14 x 1.5
16 x 2.0	24 mm	169	125	234	173	181	133	250	184	16 x 1.5
18 x 2.5	27 mm	234	172	323	239	263	194	363	268	18 x 1.5
20 x 2.5	30 mm	330	244	457	337	367	270	507	374	20 x 1.5
22 x 2.5	34 mm	451	332	623	460	495	365	684	505	22 x 1.5
24 x 3.0	36 mm	571	421	790	583	623	459	861	635	24 x 2.0
30 x 3.0	46 mm	1175	867	1626	1199	1258	928	1740	1283	30 x 2.0



**LANDHONOR INDUSTRY**

**Tel: 1-800-649-8017**

**Business: [sales@landhonor.com](mailto:sales@landhonor.com)**

**Service: [service@landhonor.com](mailto:service@landhonor.com)**

**Website: [www.landhonor.com](http://www.landhonor.com)**